

REVISIONS		
REV.	DESCRIPTION	DATE
1	ADDED (4) 6435K15 LOCK COLLARS, REMOVED (4) 90692A742 1/4" ROLL PINS, REMOVED (2) 90126A035 5/16" WASHERS	6/2/2014
2	UPDATED BOM ORDER TO MATCH 1ST FLOW MARK-UP	12/11/2014
3	UPDATED 90108A033 QTY. 14 TO 11, UPDATED SHIELD CALL OUTS, UPDATED DRW TITLE AND DWG. NO.	1/28/2015

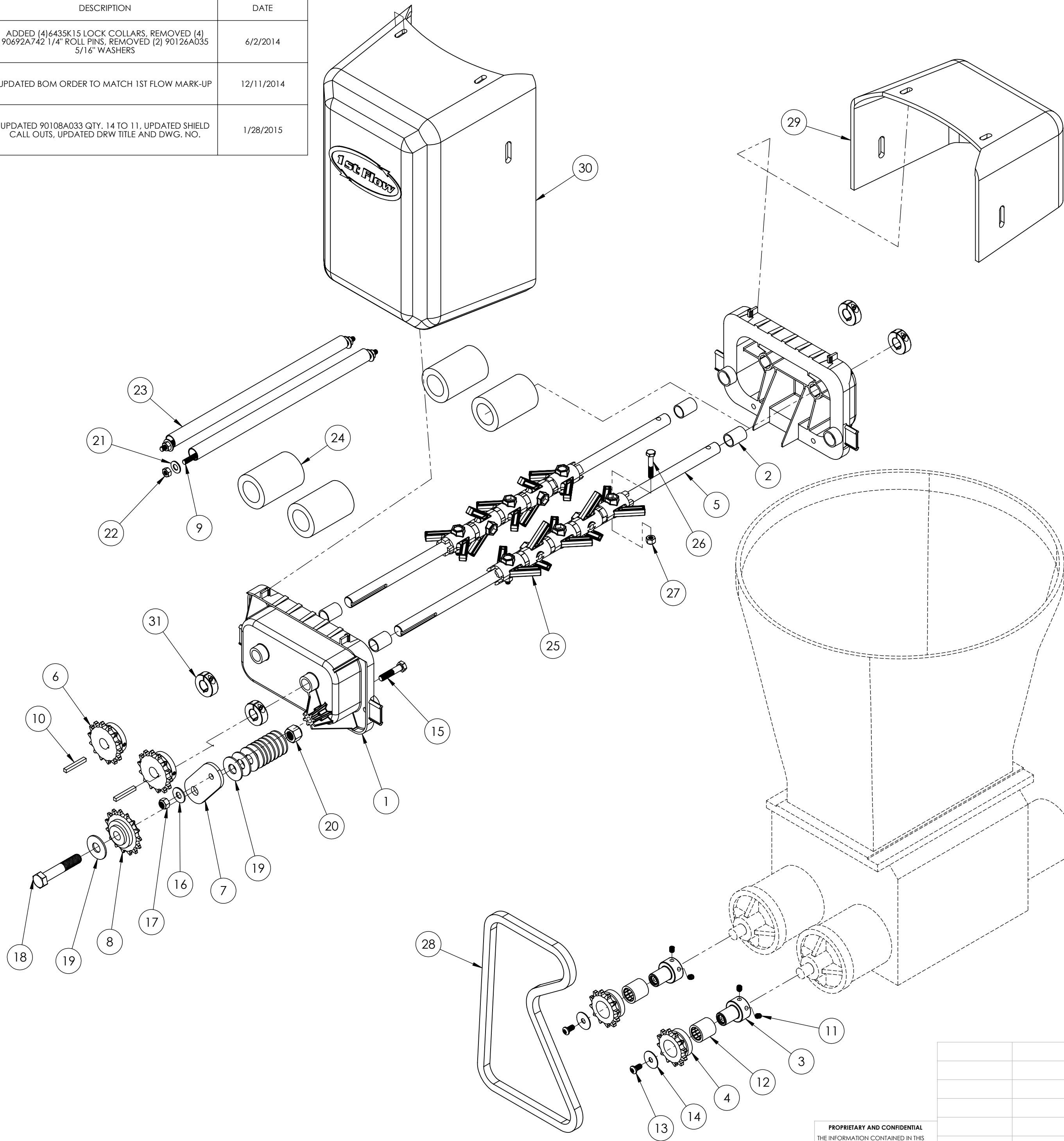

ITEM NO.	PART NUMBER	DESCRIPTION	Double/QTY.
1	END PLATE - REV 4	GUTTENBERG INDUSTRIES	2
2	9368T31	BRONZE SLEEVE BEARING	4
3	Sprocket Adapter	MACHINED INPUT SPROCKET ADAPTER	2
4	6280K665	#40 12 TEETH 1" BORE	2
5	Auger Shaft	5/8" AUGER SHAFT	2
6	6280K682	SPROCKET, 40B14	2
7	Tensioner Arm	CHAIN TENSIONER ARM	1
8	6663K130	CHAIN TENSIONER, #40/41 CHAIN, 15 TEETH, .506" BORE	1
9	98935A205	ACME, THREAD ROD, 1/4-16 X 14.50 (6FT)	2
10	98535A440	KEY, 3/16 SQ X 1.50 (3FT)	2
11	91375A557	SET SCREW, CUP POINT, 1/4"-28 THREAD, 5/16" LONG	4
12	RCB-121616	2489K6 - 1 WAY NEEDLE BEARING	2
13	91255A553	BUTTON HEAD 1/4"-28 X 1/2"	2
14	91090A108	WASHER, FENDER, 1" O.D X 1/4" ID	2
15	91247A587	BOLT, HEXHD 5/16-18 X 1.50, PARTIAL THREAD	1
16	91081A130	WASHER, 5/16 USS TYPE A	1
17	90640A130	NUT, HEX NYLON LOCK, 5/16-18	1
18	91247A723	BOLT, HEXHD, 1/2-13 X 2 3/4, PARTIAL THREAD	1
19	90108A033	WASHER, 1/2" USS TYPE A	11
20	90640A133	NUT, HEX NYLON LOCK, 1/2-13	1
21	91083A030	WASHER, 5/16 SAE	4
22	94815A007	NUT, ACME, 1/4-16 RH	4
23	7126K1	EMT, 1/2 X 13.00 (10FT LENGTH)	2
24	4463K126	TUBE, FOAM, 1-1/8" ID X 3/8" WALL (6FT)	4
25	Small Auger Section-2	GUTTENBERG INDUSTRIES	10
26	91247A546	BOLT, HEXHD, 1/4-20 X 1.50 (PARTIAL THREAD)	4
27	90640A129	NUT, HEX NYLON LOCK, 1/4-20	4
28	1170T53	CHAIN, #40 ROLLER X 70 LINKS, WITH CONNECTOR LINK	1
29	THERMOFORMED SHIELD - 1/2 SHIELD	PRAIRIE PLASTICS	1
30	THERMOFORMED SHIELD - FULL SHIELD	PRAIRIE PLASTICS	1
31	6435K15	COLLAR, CLAMP, 5/8" SHAFT	4

PROPRIETARY AND CONFIDENTIAL
 THE INFORMATION CONTAINED IN THIS DRAWING IS THE SOLE PROPERTY OF <INSERT COMPANY NAME HERE>. ANY REPRODUCTION IN PART OR AS A WHOLE WITHOUT THE WRITTEN PERMISSION OF <INSERT COMPANY NAME HERE> IS PROHIBITED.

UNLESS OTHERWISE SPECIFIED:		NAME	DATE
DIMENSIONS ARE IN INCHES	DRAWN		
TOLERANCES:	CHECKED		
FRACTIONAL: ±	ENG APPR.		
ANGULAR: ±	MFG APPR.		
TWO PLACE DECIMAL ±	Q.A.		
THREE PLACE DECIMAL ±	COMMENTS:		
INTERPRET GEOMETRIC TOLERANCING PER: MATERIAL			
FINISH			
APPLICATION	DO NOT SCALE DRAWING		

TITLE:		
1ST FLOW PRODUCTION ASSEMBLY, DOUBLE AUGER		
SIZE	DWG. NO.	REV
C	KIT-1	3
SCALE: 1:4	WEIGHT:	SHEET 1 OF 1